

3 Terms and definitions

For the purposes of this standard the following term applies.

undercut

clearance groove of specified form and dimensions created by removing material at an inner corner of a rotationally symmetric workpiece and which is necessary for subsequent machining and assembly with mating parts

4 Dimensions

4.1 Type E undercuts

Type E undercuts are suitable where the planar surface is not subjected to high fatigue loads and where the cylindrical surface will be subsequently machined if necessary. They are also suitable where mating parts have a relatively large counterbore or will not be in contact with the planar surface.

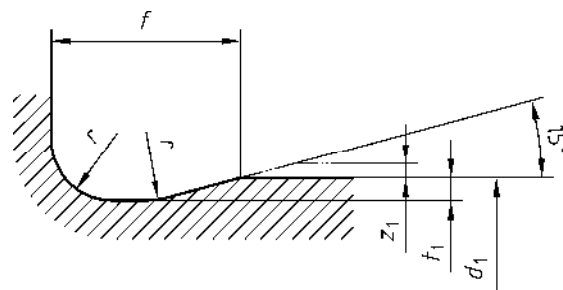

Key

- d_1 workpiece diameter
- f width of undercut
- r radius of undercut
- t_1 depth of recess
- z_1 machining allowance

Figure 1 — Undercut for workpieces with cylindrical surface intended for subsequent machining

4.2 Type F undercuts

Type F undercuts are to be used on workpieces with surfaces that are perpendicular to each other and will be subsequently machined, if necessary.

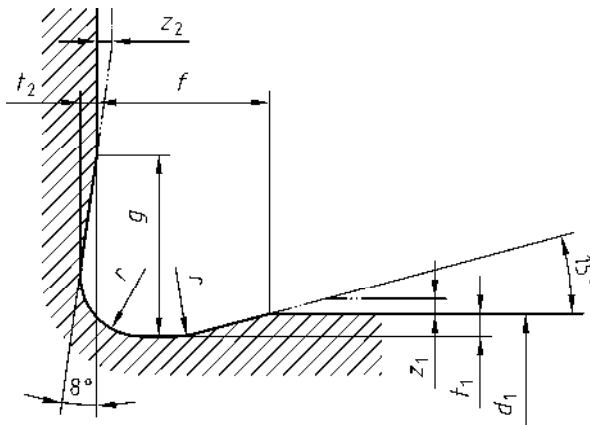

Key

- d_1 workpiece diameter
- f, g width of undercut
- r radius of undercut
- t_1, t_2 depth of recess
- z_1, z_2 machining allowances

Figure 2 — Undercut for workpieces with planar and cylindrical surfaces intended for subsequent machining

4.3 Type G undercuts

Type G undercuts are to be used on workpieces which are not subjected to high fatigue loads and where a small included angle is required.

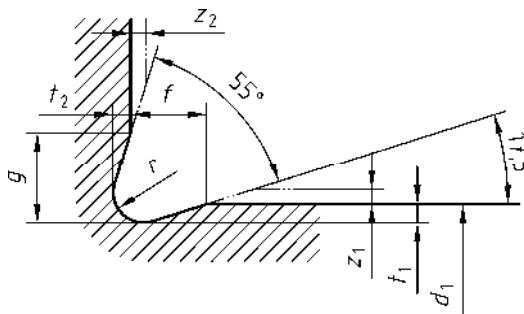

Key

- d_1 workpiece diameter
- f, g width of undercut
- r radius of undercut
- t_1, t_2 depth of recess
- z_1, z_2 machining allowances

Figure 3 — Undercut with small included angle

4.4 Type H undercuts

Type H undercuts are to be used on workpieces with surfaces that are perpendicular to each other and will be subsequently machined if necessary (but with a greater included angle).

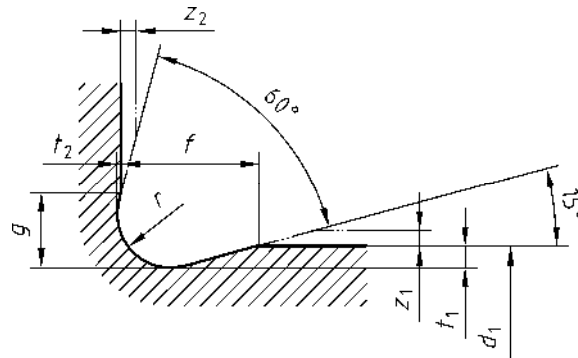

Key

d_1	workpiece diameter
f, g	width of undercut
r	radius of undercut
t_1, t_2	depth of recess
z_1, z_2	machining allowances

Figure 4 — Undercut with large included angle

5 Surface roughness

Ra 3,2; Rz1max 25

NOTE In practice the surface of undercuts can only be checked by visual inspection.

Any other roughness parameters shall be subject to agreement taking part function into consideration.

6 Designation

The designation of undercuts shall include the following elements:

- the term “Undercut”;
- the number of this standard, “DIN 509”;
- a hyphen;
- designation of the form by the relevant letter;
- the undercut size (radius r and depth t_1 separated by “x”);
- any surface roughness parameters.

EXAMPLE 1 Designation of a type E undercut having a radius, r , of 0,8 mm and a depth, t_1 , of 0,3 mm:

Undercut DIN 509 – E 0,8 × 0,3

EXAMPLE 2 Designation of a type E undercut having a radius, r , of 0,8 mm and a depth, t_1 , of 0,3 mm, material removal required (MRR as in DIN EN ISO 1302), and with Ra 1,6 μm and Rz1max 16 μm :

Undercut DIN 509 – E 0,8 × 0,3 – MRR Ra 1,6; Rz1max 16

Table 1 – Undercut dimensions

Dimensions in mm

Type	r^a $\pm 0,1$		t_1 +0,1 0	t_2 +0,05 0	f +0,2 0	g	Corresponding diameter d_1^b for workpieces	
	Series 1	Series 2					subjected to normal loads ^c	subjected to higher alternating loads
E		R0,2	0,1	–	1	–	Over Ø 1,6 up to Ø 3	–
		R0,4	0,2	–	2	–	Over Ø 3 up to Ø 18	–
		R0,6	0,2	–	2	–	Over Ø 10 up to Ø 18	–
		R0,6	0,3	–	2,5	–	Over Ø 18 up to Ø 80	–
		R0,8	0,3	–	2,5	–	Over Ø 18 up to Ø 80	–
		R1	0,2	–	2,5	–	–	Over Ø 18 up to Ø 50
		R1	0,4	–	4	–	Over Ø 80	–
		R1,2	0,2	–	2,5	–	–	Over Ø 18 up to Ø 50
		R1,2	0,4	–	4	–	Over Ø 80	–
		R1,6	0,3	–	4	–	–	Over Ø 50 up to Ø 80
		R2,5	0,4	–	5	–	–	Over Ø 80 up to Ø 125
	R4	0,5	–	7	–	–	Over Ø 125	
F		R0,2	0,1	0,1	1	(0,9)	Over Ø 1,6 up to Ø 3	–
		R0,4	0,2	0,1	2	(1,1)	Over Ø 3 up to Ø 18	–
		R0,6	0,2	0,1	2	(1,4)	Over Ø 10 up to Ø 18	–
		R0,6	0,3	0,2	2,5	(2,1)	Over Ø 18 up to Ø 80	–
		R0,8	0,3	0,2	2,5	(2,3)	Over Ø 18 up to Ø 80	–
		R1	0,2	0,1	2,5	(1,8)	–	Over Ø 18 up to Ø 50
		R1	0,4	0,3	4	(3,2)	Over Ø 80	–
		R1,2	0,2	0,1	2,5	(2)	–	Over Ø 18 up to Ø 50
		R1,2	0,4	0,3	4	(3,4)	Over Ø 80	–
		R1,6	0,3	0,2	4	(3,1)	–	Over Ø 50 up to Ø 80
		R2,5	0,4	0,3	5	(4,8)	–	Over Ø 80 up to Ø 125
	R4	0,5	0,3	7	(6,4)	–	Over Ø 125	
G	R0,4		0,2	0,2	(0,9)	(1,1)	Over Ø 3 up to Ø 18	–
H	R0,8		0,3	0,05	(2,0)	(1,1)	Over Ø 18 up to Ø 80	–
	R1,2		0,3	0,05	(2,4)	(1,5)	–	Over Ø 18 up to Ø 50

^a Undercuts with series 1 radii (as in DIN 250) are to be given preference.

^b Does not apply to parts with a short shoulder and thin-walled parts. When a workpiece has different diameters, it may be expedient for manufacturing reasons to use several undercuts having the same form and size.

^c Type G applies only to workpieces which are not subjected to high fatigue loads.

7 Machining allowances

The machining allowances z_1 and z_2 specified in Table 2 offset the transition of the undercut to the machining surfaces by dimensions e_1 and e_2 , respectively, which are in turn determined by the magnitude of the allowances and the relevant sidewall angles of the undercut.

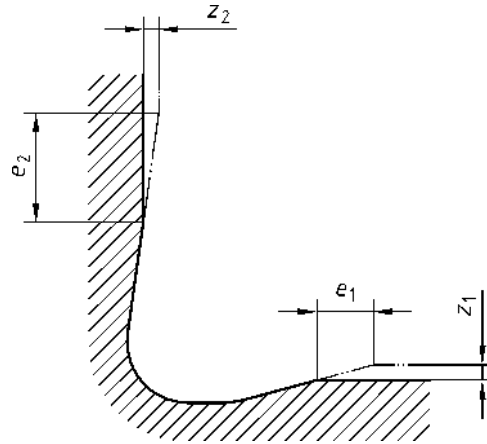

Key

e_1, e_2 transition offset
 z_1, z_2 machining allowances

Figure 5 — Machining allowances, Type F undercut

Table 1 — Machining allowances and dimensions e_1 and e_2

Dimensions in mm

z_1, z_2	Type E	Type F		Type G	Type H
	e_1	e_1	e_2	e_1 and e_2	e_1 and e_2
0,1	0,37	0,37	0,71	0,32	0,37
0,15	0,56	0,56	1,07	0,48	0,56
0,2	0,75	0,75	1,42	0,63	0,75
0,25	0,93	0,93	1,78	0,79	0,93
0,3	1,12	1,12	2,14	0,95	1,12
0,4	1,49	1,49	2,85	1,27	1,49
0,5	1,87	1,87	3,56	1,59	1,87
0,6	2,24	2,24	4,27	1,9	2,24
0,7	2,61	2,61	4,98	2,22	2,61
0,8	2,99	2,99	5,69	2,54	2,99
0,9	3,36	3,36	6,4	2,85	3,36
1,0	3,73	3,73	7,12	3,17	3,73

8 Counterbores on mating parts

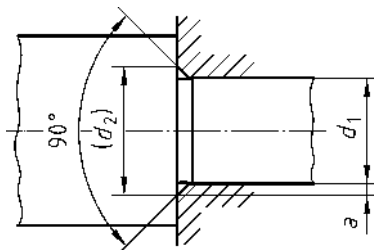

Key

a counterbore dimension

d_1 workpiece diameter

$d_2 = d_1 + 2a$

Figure 6 — Counterbore on mating part

Table 2 — Dimension a

Dimensions in mm

Undercut size $r \times t_1$	Minimum dimension a for type			
	E	F	G	H
0,2 × 0,1	0,2	0	–	–
0,4 × 0,2	0,3	0	0	–
0,6 × 0,2	0,5	0,15	–	–
0,6 × 0,3	0,4	0	–	–
0,8 × 0,3	0,6	0,05	–	0,35
1,0 × 0,2	0,9	0,45	–	–
1,0 × 0,4	0,7	0	–	–
1,2 × 0,2	1,1	0,6	–	–
1,2 × 0,3	–	–	–	0,65
1,2 × 0,4	0,9	0,1	–	–
1,6 × 0,3	1,4	0,6	–	–
2,5 × 0,4	2,2	1,0	–	–
4,0 × 0,5	3,6	2,1	–	–

9 Indications on drawings

Undercuts shown in technical drawings shall preferably be drawn using a continuous wide line, type 01.2 as in DIN ISO 128-24. Designations shall be given in conjunction with a leader line and reference line as in DIN ISO 128-22 (see Figures 7 and 8). Figures 9 and 10 show how to present full details.

EXAMPLE 1 Undercut F 1,2 × 0,2

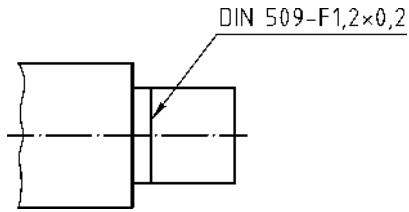

Figure 7 — Simplified representation of undercut F 1,2 × 0,2

EXAMPLE 2 Undercut E 1,2 × 0,2

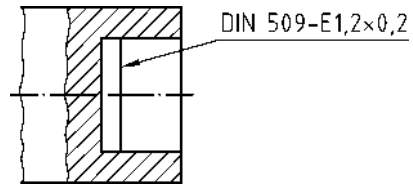
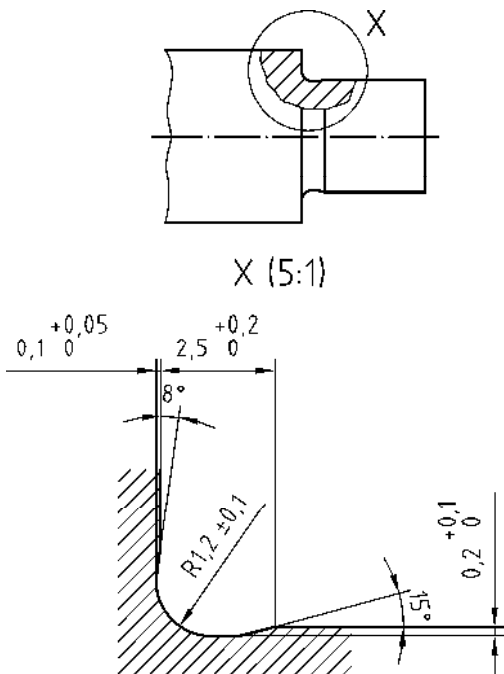

Figure 8 — Simplified representation of undercut E 1,2 × 0,2

Dimensions in mm



NOTE Surface roughness information as in Clause 5 of this standard or as in DIN EN ISO 1302

Figure 9 — Detailed representation of undercut F 1,2 × 0,2

Dimensions in mm

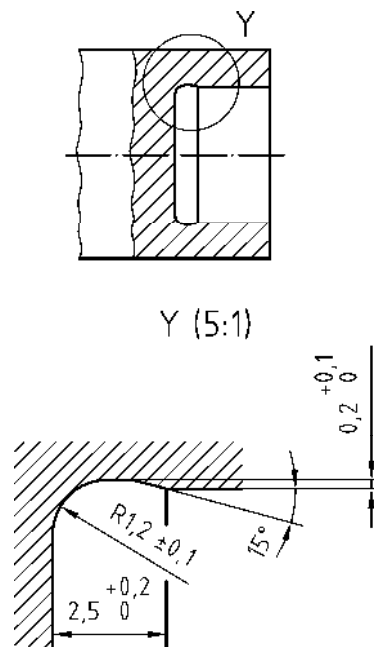

NOTE Surface roughness information as in Clause 5 of this standard or as in DIN EN ISO 1302

Figure 10 — Detailed representation of undercut E 1,2 × 0,2